

QCLVDS3-065U

*Low Voltage Differential Signaling (LVDS) Transceiver,
1.015 GHz, 1.2v/2.5v Pad using 1.2v/2.5v, Logic Mixed
Mode Low Leakage process*



General Description

The QCLVDS3-065U is a transceiver that provides CMOS to LVDS then back to CMOS signal level translation. It provides a high-speed (1.015GHz) data rate interface between devices operating at CMOS logic levels but communicating between each other at LVDS logic levels, thus assuring a high rate of data transfer. LVDS is a low swing, differential signaling technology. The low swing and current mode driver outputs create low noise and provide with very low power consumption across different frequencies.

Features

- Designed for a 0.065 μ m, 1P10M, Logic Mixed Mode, Low Leakage 1.2V/2.5V process
- Cell uses 1P6M
- Size of each I/O – 70um x 280 um
- Operates at speeds up to 1.015GHz
- Antenna diodes on all core digital inputs
- Pads incorporate ESD structures
- IO uses Rvt and Hvt MOS devices
- IO uses Bonded Over Active Circuit (BOAC) pad.

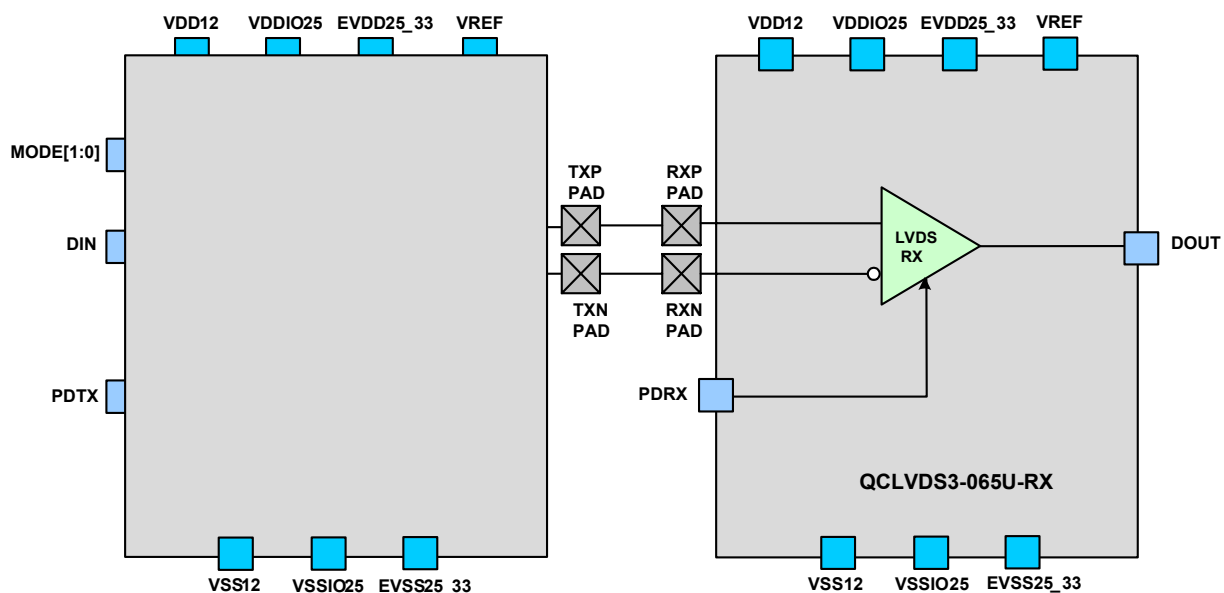

Figure 1. QCLVDS3-065U Block Diagram